

When It's Done Right...It's Golden!



# ***4.5K THRU 28K 4 POST 2 MOTOR OWNERS MANUAL***



17611 East Street, North Fort Myers, FL 33917

TF: 888-909-5438 PH: 239-337-4141 FAX: 239-337-4482 [www.goldenboatlifts.com](http://www.goldenboatlifts.com)

DEALER \_\_\_\_\_ INSTALLATION DATE \_\_\_\_\_

OWNER'S NAME \_\_\_\_\_

SERIAL NUMBER \_\_\_\_\_

## CONGRATULATIONS ON YOUR PURCHASE OF A GOLDEN 4 POST, 2 MOTOR LIFT!

We appreciate your business and want you to know that you have purchased the finest boat lift on the market today.

This owner's manual is designed to provide vital information on safety, operation and maintenance of your new lift.

**WHEN IT'S DONE RIGHT... IT'S GOLDEN!**

 **CAUTION: READ OPERATING INSTRUCTIONS CAREFULLY!**

### **Precautions Before Operating The Lift System**

- Never leave the lift unattended while in operation.
- Be sure the boat stays level when raising or lowering the boat.
- Do not run the cradles down allowing the cables to slack.
- If the cables go slack be sure to realign and tighten the cables before lifting the boat.
- Keep hands clear of moving parts.
- Do not exceed the rated capacity.
- Boat lifts are not intended for lifting humans.
- Do not operate the boat lift without a G.F.C.I.
- The lift **MUST** be wired by a licensed electrician.
- Inspect and lubricate all grease fittings periodically.
- Inspect the cables before each use.
- The boat lift must be operated by an adult.
- Be sure the center of gravity of your boat is in the center of the lift.
- Do not operate the lift without the protective covers in place.
- **DO NOT WORK ON YOUR BOAT OR GO UNDER IT WHEN THE BOAT IS ON THE LIFT.**
- **NOTE:**
  - (1) The boat lift cradles must be lowered to a point that is below the draft of the boat before you drive the boat over the boat lift cradle.
  - (2) When you raise the boat lift you must raise the cradle up far enough so the cradle is away from the highest point of water may reach.

YOU MUST COMPLY WITH THE WARNINGS TO PREVENT INJURY TO A PERSON OR DAMAGE TO YOUR BOAT.



17611 East Street, North Fort Myers, FL 33917

TF: 888-909-5438 PH: 239-337-4141 FAX: 239-337-4482 [www.goldenboatlifts.com](http://www.goldenboatlifts.com)

# BOAT LIFT MAINTENANCE SEA DRIVE

Grease each bearing located in front and behind each winder and at the very front by the gear box.

5 Places each top beam

**SEA DRIVE**  
Gear box and motor  
do not require service.

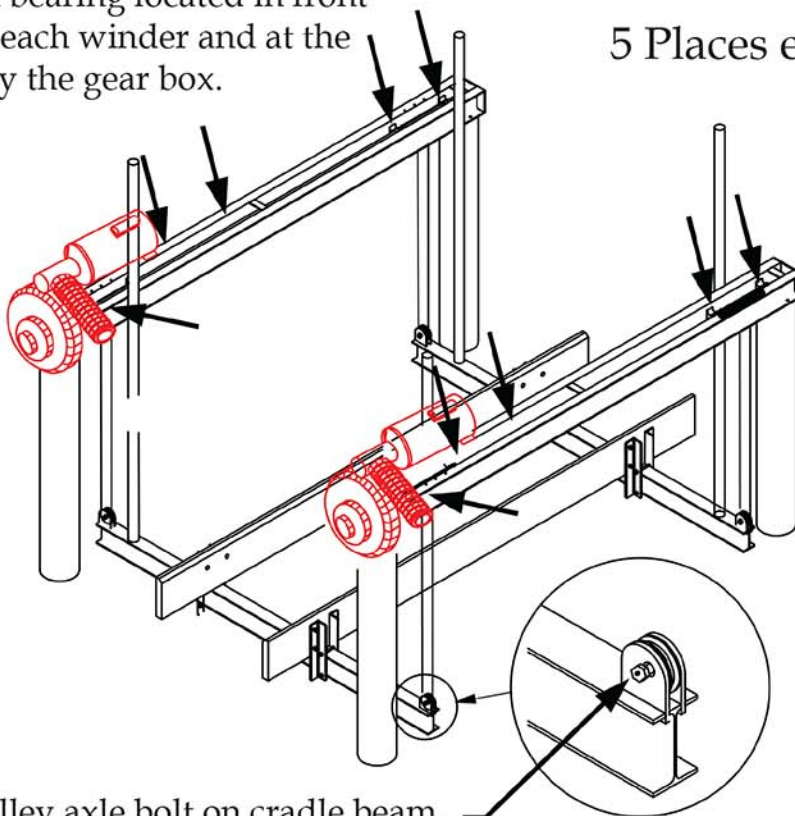

Grease each pulley axle bolt on cradle beam.  
Inspect pulley and cable for wear. Replace if damaged.

## TO KEEP YOUR LIFT IN OPERATING SERVICE

1. Grease all fittings with high temperature (550), water resistant, high impact grease.
2. Inspect all stainless steel cable for fraying, kinking. It is helpful to take a soft cotton cloth and rub down the cables where they experience both the winder and the pulley. The cloth will catch on any broken fibers.
3. Inspect all electrical components and wiring. Replace if damaged or worn.
4. Rinse all cables, pulleys and submersible parts with fresh water after use.

Under no circumstances will warranty coverage extend to damage caused by ELECTROLYSIS. Keep the lift's electrical connection off when not in use.



17611 East Street, North Fort Myers, FL 33917

TF: 888-909-5438 PH: 239-337-4141 FAX: 239-337-4482 [www.goldenboatlifts.com](http://www.goldenboatlifts.com)

# BOAT LIFT MAINTENANCE FLAT PLATE DRIVE

Grease each bearing located in front and behind each winder and at the very front by the gear box.

Remove the flat plate cover.  
Grease bearings at the worm gear.  
Pack drive gear with grease and grease the fitting behind the drive gear.  
Inspect drive for wear, tighten if loose.

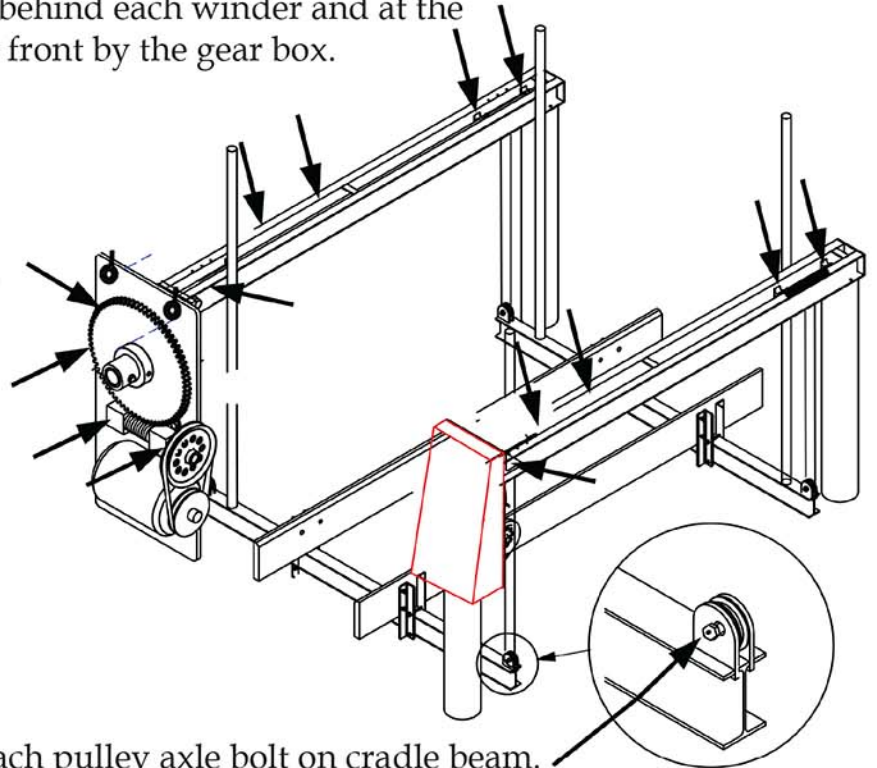

Grease each pulley axle bolt on cradle beam.  
Inspect pulley and cable for wear. Replace if damaged.

## TO KEEP YOUR LIFT IN OPERATING SERVICE

1. Grease all fittings with high temperature (550), water resistant, high impact grease.
2. Inspect all stainless steel cable for fraying, kinking. It is helpful to take a soft cotton cloth and rub down the cables where they experience both the winder and the pulley. The cloth will catch on any broken fibers.
3. Inspect all electrical components and wiring. Replace if damaged or worn.
4. Rinse all cables, pulleys and submersible parts with fresh water after use.

Under no circumstances will warranty coverage extend to damage caused by ELECTROLYSIS. Keep the lift's electrical connection off when not in use.



17611 East Street, North Fort Myers, FL 33917

TF: 888-909-5438 PH: 239-337-4141 FAX: 239-337-4482 [www.goldenboatlifts.com](http://www.goldenboatlifts.com)

# WEIGHT DISTRIBUTION

The weight of your boat must be equally distributed on the beams to ensure your safety, the boat hull and longevity of the lift.

Always place the center of gravity of your boat directly in the CENTER of the lift beams.

Please consult your installer and boat manufacturer for proper bunking of the hull on the lift support equipment.

The bunk boards were adjusted to fit a single hull and are NOT interchangeable. For a different boat re-adjust the bunk boards.

See the illustration below for further instructions on loading your boat.

The center of gravity of your boat as a rule of thumb is about 1/3 distance from the stern and 2/3 distance from the bow. Your boat manufacturer can tell you the exact location. In the illustration below depicting the lift center equal distance side to side and front to back.

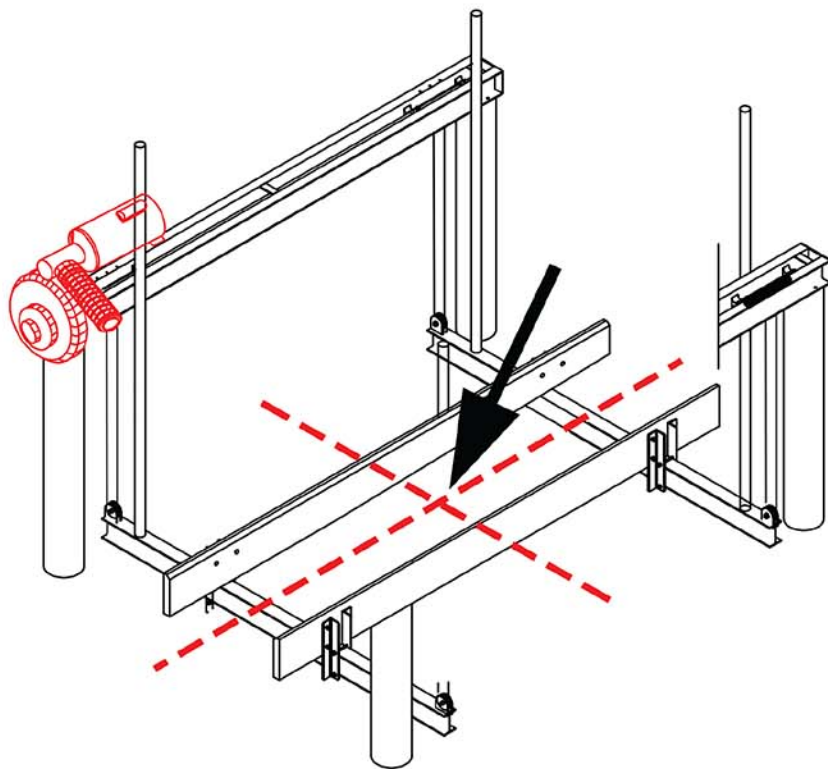

17611 East Street, North Fort Myers, FL 33917

TF: 888-909-5438 PH: 239-337-4141 FAX: 239-337-4482 [www.goldenboatlifts.com](http://www.goldenboatlifts.com)

# GENERAL INFORMATION

Golden Boat Lifts, Inc. Warranty is the longest and most comprehensive warranty in the industry. Our lift is simple to maintain and the most reliable lift in the industry. We are very proud of our product. Golden Manufacturing asks that you grease the easily accessed fittings and check the cables. All other components are maintenance free.

The electrical controls and optional remote control information is covered in the electrical control Manufacturer's information package. You may consult their website for additional information covering their product.

If your lift has an optional Auto-Stop the installer will make adjustments at the time of the installation. However, if additional adjustments are required we recommend having this done professionally.

## ACCESSORIES FOR YOUR LIFT

- Walkways and boarding platforms
- Top beam covers
- Platforms
- Accent LED lighting
- Walkway steps
- Cable Keeper cable extension device
- Motor covers

**Consult our website: [Goldenboatlifts.com](http://Goldenboatlifts.com) for the latest information and accessories.**

**Enjoy The Golden Experience!**



17611 East Street, North Fort Myers, FL 33917

TF: 888-909-5438 🌐 PH: 239-337-4141 🌐 FAX: 239-337-4482 🌐 [www.goldenboatlifts.com](http://www.goldenboatlifts.com)